

Impresso Bucket Label Applicator and Conveyor

Modular 20" Unwind/Rewind Label Applicator

High Performance - Reliable - Cost Effective

- 1** Customizable computer controls with separate enclosed on-board panel



All-in-one self-contained electronics software platform is flexible to run many different types of applications.

- 2** Brushless Servo Motor for long life.

The Impresso Labeler and the Bucket Drive Roller utilize a brushless servo motor for accurate placement and precise control. 1000 watt motors are available for the most demanding applications. Motor upgrades are available depending on the application.

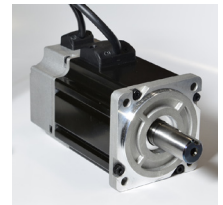

- 3** Transports buckets while precisely applying labels

The Bucket Drive Roller next to the peel plate rotates the bucket as the label applicator applies the label. A centering assembly opposite the Bucket Drive Roller extends towards the bucket and holds it in place as labels are adhered.

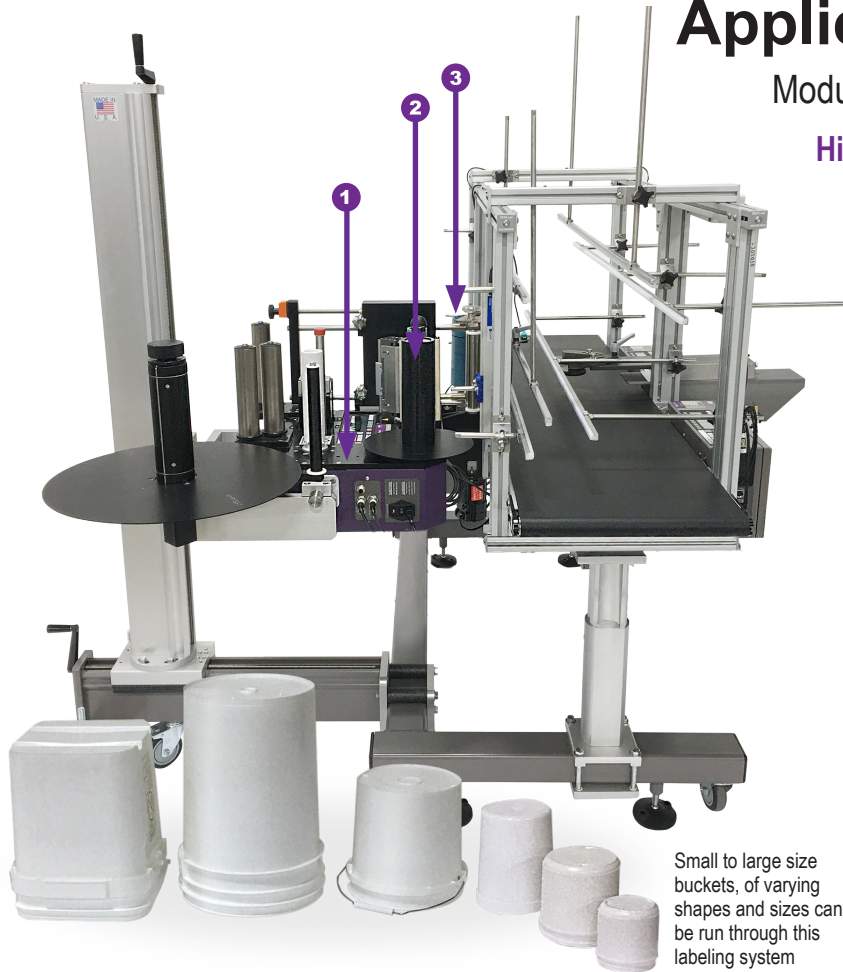
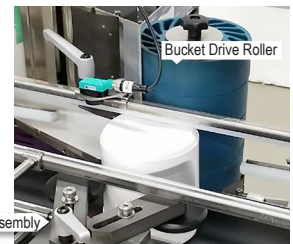

Small to large size buckets, of varying shapes and sizes can be run through this labeling system

Impresso Label Applicator and Conveyor

Features

- The Impresso Bucket Labeler precisely holds, and rotates, the container simultaneously in place while accurately applying labels being transported down a conveyor.
- A flexible system running a wide variety of round or rectangular buckets and label sizes. Set product length, label position, and calibrate.
- Left, right and top guide rails provide precise product control for different size containers.
- Labeler system accommodates wrap-around labels onto a round bucket and flat side labels onto rectangular buckets.
- Changeover is quick and easy and can be performed tool-less, use quick lock handles for adjustments. Simply unscrew to a new position and lock down.
- Stand-alone labeler or integrates with existing production lines to create a production system.
- Highly adaptable software package integrates multiple inputs to achieve accurate label placement at high speeds. Label detection and variable speed correction available with Accutipping.
- Small compact versatile design handles up to a 20" diameter roll of labels; 4" or 8" wide available.

Industries:

- Pharma/Medical
- Cosmetics
- Financial
- Robotics
- Food
- Packaging
- Printing

Applications

- Adhere labels to buckets, tubs, packaging, cartons, boxes, folders and more.

Technical Data: Impresso Bucket Label Applicator and Conveyor

Equipment Specifications

Typical Height	1922mm (75.6")
Typical Length	2037mm (80.2")
Typical Width	2107mm (82.9")
Maximum Speed**	Dependent on product size
Power Requirements	110/220V 50-60Hz 6A
Operating Temp.*	10°-35°C (50°-95°F)
Weight Ranges	greater than 250 lbs.

*All MFT Automation equipment can be designed to meet your specific production requirements. Please contact one of our experienced Application Engineers to discuss many solution options available to you.

**Subject to product review, dependent on product size, label size, label application format and other application.

Label Specifications

Minimum Size	10mm† (W) x 10mm (L)
Maximum Size 4 inch width*	100mm (W) x 1000mm (L)
Maximum Size 8 inch width*	203mm (W) x 1000mm (L)

*All MFT Automation equipment can be designed to meet your specific production requirements. Please contact one of our experienced Application Engineers to discuss many solution options available to you.



Standard Dimensional Drawing

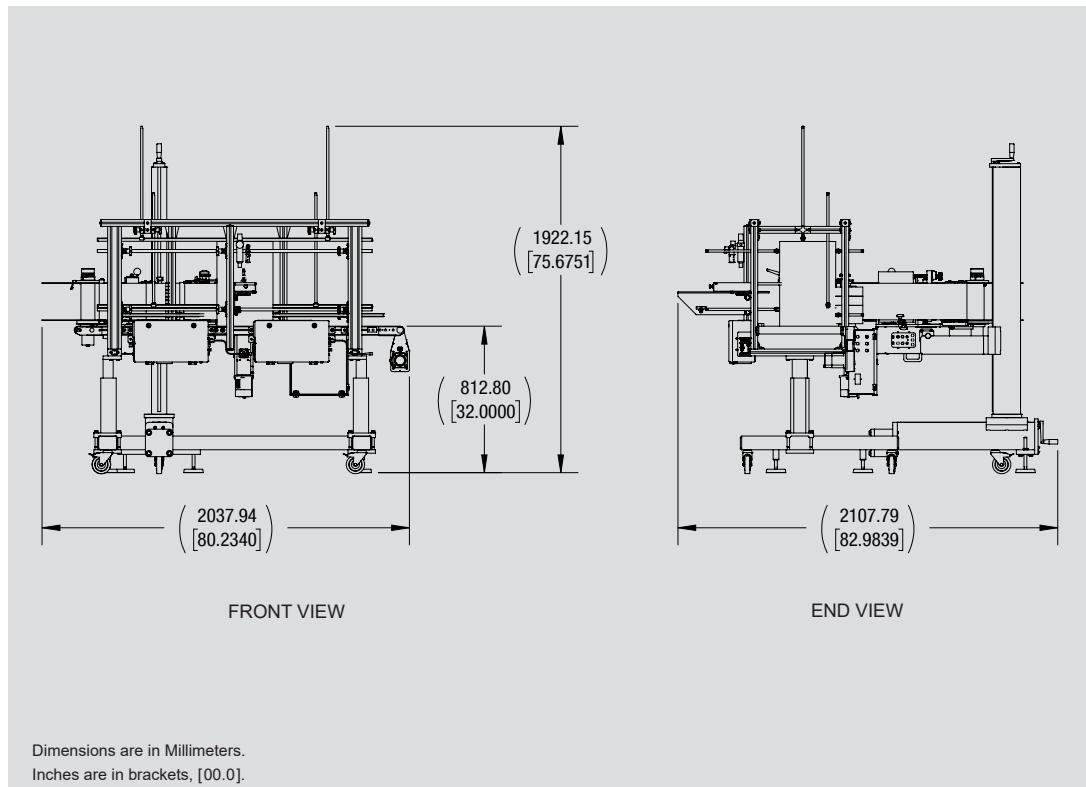

All specifications are subject to change without notice.

Technical Support Services



Our dedicated team of experienced Technicians and Application Engineers have the proper training and necessary credentials to answer any questions and offer system solution recommendations for your project needs.

For Technical Assistance, call 651-407-3100, select option 2.

MFT Automation provides high performance friction feeding and labeling solutions throughout the world. With state-of-the-art control technology and robust mechanics, our products feed and label more quickly and accurately to provide customers with a greater value of return. All feeders, labelers and accessories can easily be integrated with other machines to provide a total system solution for any application.



www.mftautomation.com

MFT AUTOMATION
4821 WHITE BEAR PARKWAY
ST. PAUL, MN 55110
© 2021 MFT AUTOMATION

PHONE: 651-407-3100
FAX: 651-407-3199
MARKETING@MULTIFEEDER.COM
10/2021 SELL SHEET #111