

Automatic Product Loader (APL)

High Performance - Reliable - Cost Effective



1 Forward and Reverse Directional Control



The APL controller allows for forward or reverse directions. Circuitry is enclosed in a sealed electrical box for protection.

2 APL System Configuration either 90 (degree) or 180 (degree)



The APL system can be integrated into a 90 (degree) configuration for special applications or space saving needs.



APL shown with 250 ip3 feeder and stand

Features

- Multiplies the capacity of your feeder to increase unassisted runtime.
- Minimizes the number of operator-assisted reloads.
- Controls irregular product by spreading out product on a flat horizontal conveyor.
- Available in a variety of widths and lengths.
- 30mm support rods and linear bearings allow the APL to be easily adjusted.

Industries:

- Pharmaceutical
- Food
- Cosmetics
- Packaging
- Financial
- Printing
- Robotics

Common equipment that the APL can be integrated into:

- Imaging lines
- Shrinkwrappers
- Existing bases
- Conveyers
- Folder/Gluer
- Flow Wrappers
- Poly-baggers
- Case-packers
- Cartoners
- Order fulfillment
- Collators
- Banders

Applications

- Horizontal conveyor reloads magazine capacity.
- Reduces or eliminates operator-assisted reloads.
- Large product volume, oversized products or increased conveying speed.

Technical Data: Automatic Product Loader

Equipment Specifications

Typical Height	937mm (36.8")
Typical Length (ED)	2262mm (89.1")
Typical Width	540mm (21.3")
Maximum Belt Speed	140 Meters per Minute*
Power Requirements	110/220V 50-60Hz 6A
Operating Temp.	10°-35°C (50°-95°F)
Operating Humidity	30-100 NonCondensing

Product Specifications

Minimum Size	25mm† (W) x 25mm (L)
Maximum Size*	300mm (W) x 325mm (L)‡
Minimum Thickness	0.075mm (.003")

† Minimum Product Length may require narrow belt configuration.

‡ Maximum Product Length is dependent on product, equipment configuration and application.

*All MFT Automation equipment can be designed to meet your specific production requirements. Please contact one of our experienced Application Engineers to discuss many solution options available to you.

Product examples to deliver through feeder:

- Bags
- Gift Cards
- Carton Blanks
- Pouches
- Clear-Film Plastics- Coupons
- Tyvek® Sheets
- Pamphlets
- Magnets
- Pharma Inserts
- Card Stock Products
- Bandages
- And More

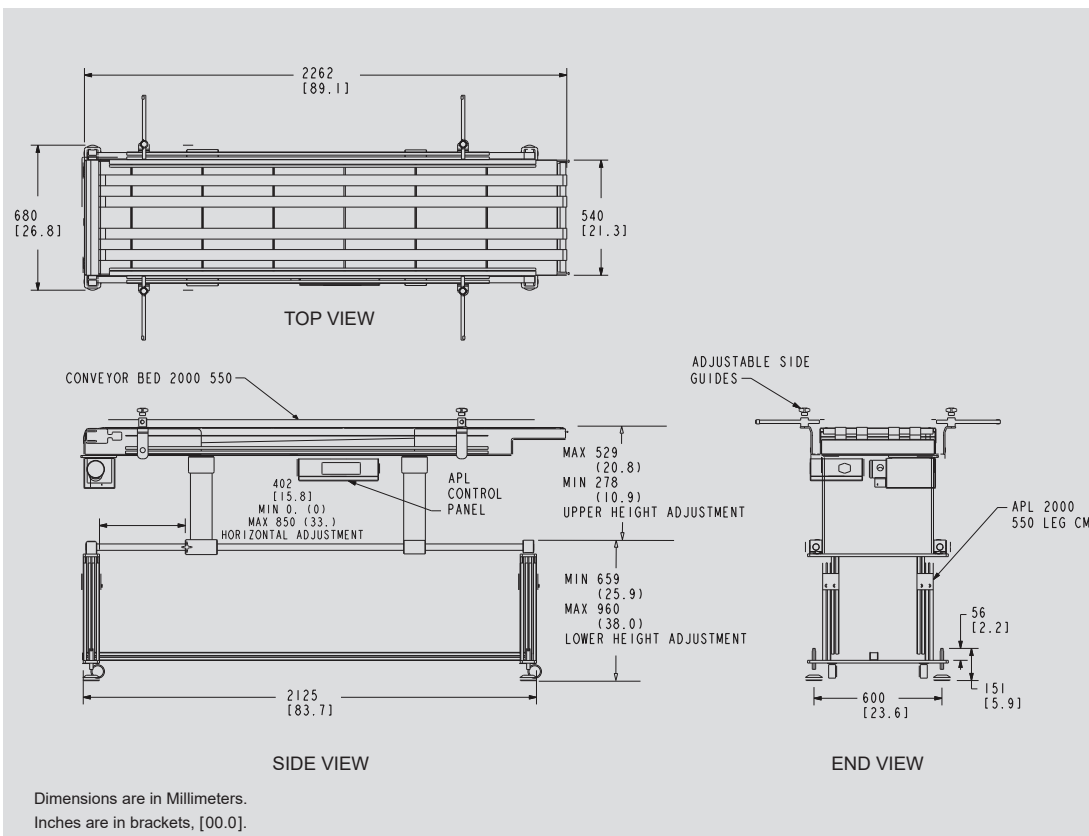

All specifications are subject to change without notice.

MFT Automation provides high performance friction feeding and labeling solutions throughout the world. With state-of-the-art control technology and robust mechanics, our products feed more quickly and accurately to provide customers with a greater value of return. All feeders, labelers and accessories can easily be integrated with other machines to provide a total system solution for any application.

Technical Support Services



Our dedicated team of experienced Technicians and Application Engineers have the proper training and necessary credentials to answer any questions and offer system solution recommendations for your project needs.

For Technical Assistance, call 651-407-3100, select option 2.

