

Industrial Performance Friction Feeder Family 200 Millimeter Width Capability

MFT 250 ip³

High Performance - Reliable - Cost Effective



1 3 Piece Shaft allowing for easy belt changeover

The hardened stainless steel shafts and sealed bearings will provide maximum life expectancy and 24-hour a day operation.

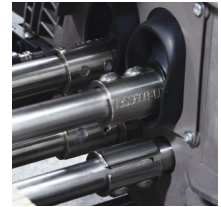

2 Brushless Servo Motor for precise placement

The ip series is powered by a 750 watt brushless servo motor. Depending on your application needs, an optional upgrade up to 1000 watts is available.

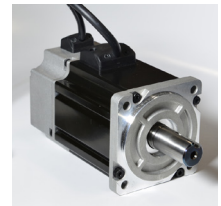

3 Self-contained computer controls with on-board panel

Multifeeder's all-in-one self-contained electronics software platform is flexible to run many different types of applications. Designed for easy interface with existing computer, PLC or other host machinery.



Friction Feeder MFT 250XED ip³ assembly unit

Features

- Mechanical design is modular for custom configurations to meet your product needs
- Highly adaptable software package ensures flexible and precise control
- Infrared sensor allows for accurate count using double-detect and overlap detection
- Single-sided controls provide for efficient operation
- Easy and versatile to interface using standard industry compliant connectors
- Performance designed for long production runs
- Patented "feed separating" mechanism
- Closed loop system with encoder feedback

Industries:

- Pharmaceutical
- Food
- Cosmetics
- Packaging
- Financial
- Printing
- Robotics

Common equipment that the feeder can be integrated into:

- Imaging lines
- Shrinkwrappers
- Existing bases
- Conveyers
- Folder/Gluer
- Flow Wrappers
- Poly-baggers
- Case-packers
- Cartoners
- Order fulfillment
- Collators
- Banders

Applications

- Insertion into a catch-tray, box or conveyor
- Deliver a product to a secondary application
- Batching, high speed tipping or affixing, collating systems and barcode/vision systems

Technical Data: MFT 250 ip³

Equipment Specifications

Typical Height	856mm (31.7")
Typical Length (ED)	645mm (25.4")
Typical Width	538mm (21.2")
Maximum Belt Speed	275 Meters per Minute*♦
Power Requirements	110/220V 50-60Hz 6A
Operating Temp.	10°-35°C (50°-95°F)
Weight Ranges	75-125 lbs.
Operating Humidity	30-90

♦ To achieve maximum linear speeds, additional options and upgrades are needed.

Product Specifications

Minimum Size	20mm† (W) x 20mm (L)
Maximum Size*	200mm (W) x 325mm (L)‡
Minimum Thickness	0.075mm (.003")
Maximum Thickness	25mm

† Minimum product length may require narrow belt configuration.

‡ Maximum Product Length is dependent on product, equipment configuration and application. Longer lengths are available with optional upgrades.

*All Multifeeder Technology® equipment can be designed to meet your specific production requirements. Please contact one of our experienced Application Engineers to discuss many solution options available to you.

Product examples to deliver through feeder:

- Bags
- Gift Cards
- Carton Blanks
- Pouches
- Clear-Film Plastics- Coupons
- Tyvek® Sheets
- Pamphlets
- Magnets
- Pharma Inserts
- Card Stock Products
- Bandages
- And more

Standard Dimensional Drawing

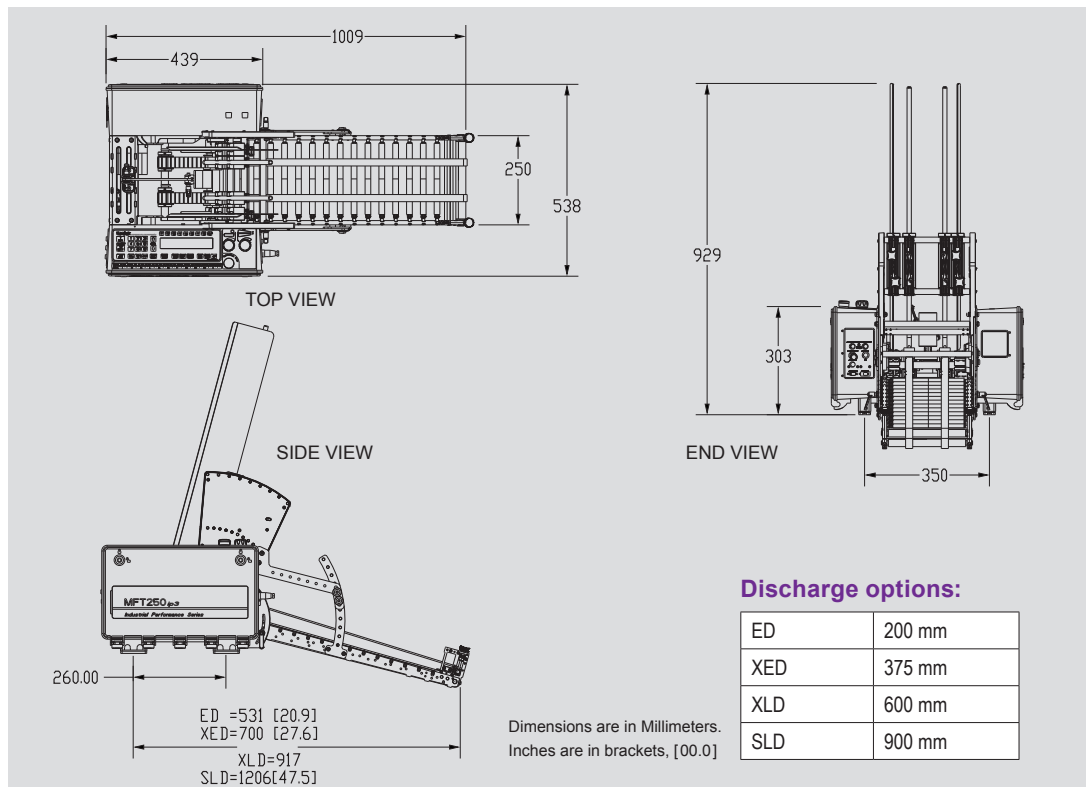

All specifications are subject to change without notice

Technical Support Services



Our dedicated team of experienced Technicians and Application Engineers have the proper training and necessary credentials to answer any questions and offer system solution recommendations for your project needs.

For Technical Assistance, call 651-407-3100, select option 2.

Multifeeder Technology provides high performance friction feeding and labeling solutions throughout the world. With state-of-the-art control technology and robust mechanics, our products feed more quickly and accurately to provide customers with a greater value of return. All feeders, labelers and accessories can easily be integrated with other machines to provide a total system solution for any application.

Multifeeder
TECHNOLOGY

www.multifeeder.com

© 2018 Multifeeder Technology

Multifeeder Technology®
4821 White Bear Parkway
St. Paul, MN 55110
Phone: 651-407-3100
Fax: 651-407-3199
marketing@multifeeder.com

2018-08 #001